

HP3-5R

(Five reinforcement profiles)

This type of pallet is ideal for the food industry, pharmaceutical logistics and for all conditions that require a perfect combination of mechanical performance and the highest health requirements. The new inner round corners ensure the smoothest transmission through automatic conveyor systems and minimize the risk of pallets getting stuck and damaged. This type of pallet has perfectly smooth and flat surfaces that prevent the accumulation of dirt and dust. This type of pallet is available in two forms, three runners or five runners.

this type of pallet with integrated reinforcement profiles is an ideal pallet in the heavy-duty category. Its strength and durability make it suitable for high racking systems and automated process.

The material used to manufacture this type of pallet is food-grade.

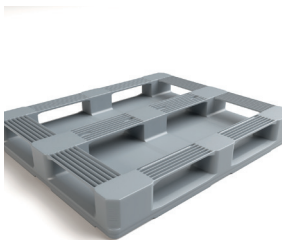
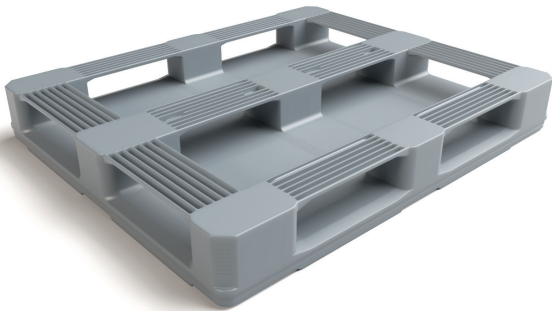

Capable of being used in racking systems due to having 5 runners

Logo print or embossment



POWER OF QUALITY



PERSIAN SANAT

Art No.
PS-1210-HP3-5R-5P
 Previous Name
HP1210/5R/5P

Net weight (kg)	29 ± 0.5
Bottom type	5 Runners
Dimension (mm)	1200×1000×160
Temperature stability (°c)	-20 To +30
Static load (kg)	7500
Dynamic load (kg)	2000
Racking load (kg)	2000
Reinforcement profiles	5
Loading quantities (pcs/approx.)	450 520
Surface type	Closed
Safety rims (mm)	7
Material	HDPE
Pallet color	Other colors on request
Logo option	Print & Embossment

the load capacities are based on an evenly distributed loads and it can vary according to the type of load.

Container 40 HC
 Jumbo Truck

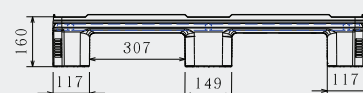
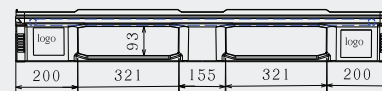
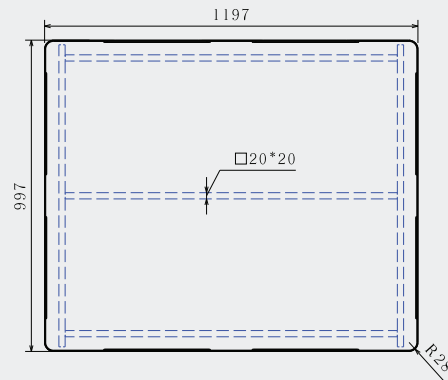

All dimensions may vary ± 5mm due to production process and raw materials characteristics.